

# Installation Manual

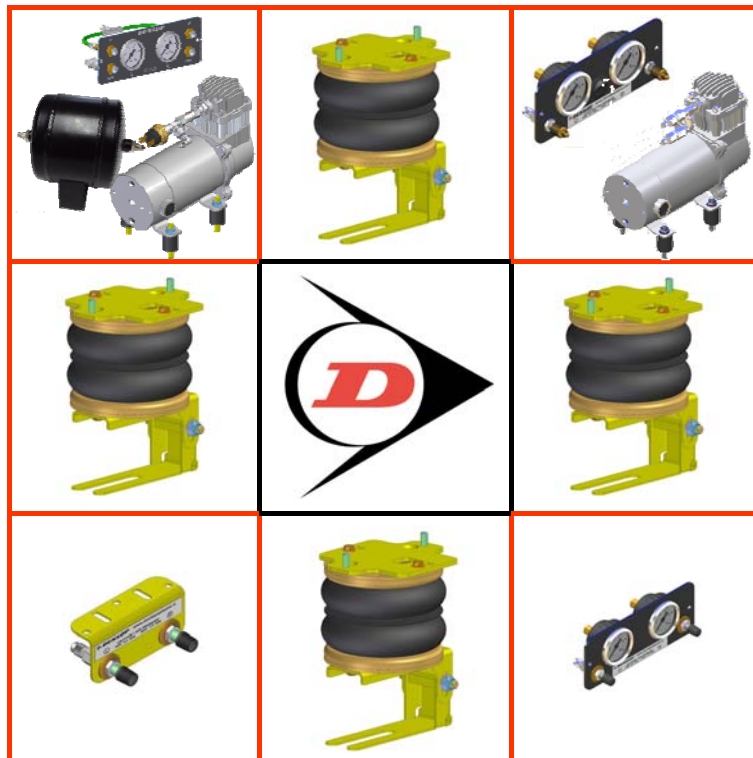

## L.NAV.14.C.M

Nissan Navara NP300  
(D23, King Cab, Leaf spring)  
2015 - onwards





D23

Nissan Navara NP300

D23

## L.NAV.14.C.M

### CONTENTS

1. FOREWORD .....	3
2. INTRODUCTION.....	4
3. VERY IMPORTANT NOTES.....	5
4. COMPLETE ASSEMBLY .....	6
5. INSTRUCTIONS FOR INSTALLATION .....	7
5.1. Recommended Tightening Torque.....	7
5.2. Preparation .....	8
5.3. Attaching top plate to chassis .....	8
5.4. Installation of lower plate.....	8
5.5. Installation of the air spring.....	8
5.6. Spring alignment .....	8
5.7. Fitting of Inflator Console.....	9
5.8. Tube Connection and Disconnection, Cutting and Routing .....	11
5.9. Spring Inflation.....	12
5.10. Maintenance .....	13
5.11. Check List .....	13
5.12. Installation Photos.....	14
6. EPILOGUE .....	16

DSC Nederland B.V.  
Het Wegdam 22  
7496 CA Hengevelde  
Nederland  
Tel. : +31 (0)547 333065  
Fax. : +31 (0)547 333068  
e-mail: [info@dunlopsystems.nl](mailto:info@dunlopsystems.nl)  
Website: [www.dunlopsystems.nl](http://www.dunlopsystems.nl)

© 2017, DSC Nederland B.V.



D23

Nissan Navara NP300

D23

## L.NAV.14.C.M

### 1. FOREWORD

This manual provides instructions for the installation of an auxiliary air suspension kit, developed specifically for the Nissan Navara NP300, King Cab with leaf springs. To ensure correct installation of the kit, it is strongly recommended that these instructions are read thoroughly before commencing any installation work. Installation should only be carried out by a suitably qualified mechanic or specialist installation facility. DSC Nederland will not accept any responsibility for faults or defects arising from incorrect installation, which automatically renders the guarantee invalid.

#### **IMPORTANT : Manufacturer's Declaration Form**

**A manufacturer's declaration form is provided with your kit. Following installation of the kit please ensure that this form is completed, signed by a qualified fitter and a copy is returned to DSC Nederland by post, fax or e-mail. Our e-mail address is: [info@dunlopsystems.nl](mailto:info@dunlopsystems.nl)**



D23

Nissan Navara NP300

D23

## L.NAV.14.C.M

### 2. INTRODUCTION

Thank you for choosing an auxiliary air suspension kit from the range offered by *DSC Nederland*. Auxiliary air suspension is fitted in tandem with the standard steel springs of the vehicle suspension, and provides enhancements in terms of both the stability of the vehicle and the comfort of the passengers...

#### **Vehicle Levelling**

Simply by varying the air pressure in the springs, the vehicle can be levelled both front-to-rear and side-to-side. Keeping the vehicle level optimises stability, ensures correct headlamp beam distribution and reduces tyre wear arising from uneven distribution of weight.

#### **Straight Line Stability**

Straight line stability is greatly increased at higher speeds, and when subjected to buffeting from cross-winds or large overtaking vehicles.

#### **Reduced Body Roll**

Body roll when cornering or negotiating roundabouts is significantly reduced.

#### **Fatigue Reduction and Wear Compensation**

Suspension fatigue is reduced, so helping to prevent leaf springs from sagging under repeated or constant loading. Any sagging already present can be compensated-for. This is a particular benefit for motorhomes, which are always fully laden.

#### **Ride Comfort**

Air springs help to absorb shock loads from uneven road surfaces, therefore general ride quality is much improved.

## L.NAV.14.C.M

### 3. VERY IMPORTANT NOTES



#### Gross Vehicle Weight (GVW)

**Air assist kits are not in themselves designed to increase the gross vehicle weight (GVW) rating of a vehicle.** They do not legally allow for carriage of a load greater than the carrying capacity stated on the data plate of the vehicle.

Do not exceed the maximum load specified by the vehicle manufacturer...

- ◆ to avoid compromising passenger safety
- ◆ to prevent possible damage to the vehicle
- ◆ for legal reasons

#### Vehicle Upgrading

Despite the above words of caution, it is possible to upgrade the weight rating of your vehicle. This must be carried-out by a specialist supplier that will...

- ◆ carry out any necessary modifications in addition to fitting the air assist kit
- ◆ complete documentation as necessary to inform the Driver and Vehicle Standards Agency (DVSA) – a mandatory requirement
- ◆ supply and fit a new weight plate to replace the original plate supplied with the vehicle

This process applies to United Kingdom registered vehicles. The process in other countries may be different.

#### Safety Guidance Note

The following very useful guidance note is available for free download from the *Health and Safety Executive (HSE)*...

**PM85, July 2007** *Safe recovery (and repair) of buses and coaches fitted with air suspension*

The uniform resource locator (URL) for this document is...

<http://www.hse.gov.uk/PUBNS/pm85.pdf>

**L.NAV.14.C.M**

**4. COMPLETE ASSEMBLY**

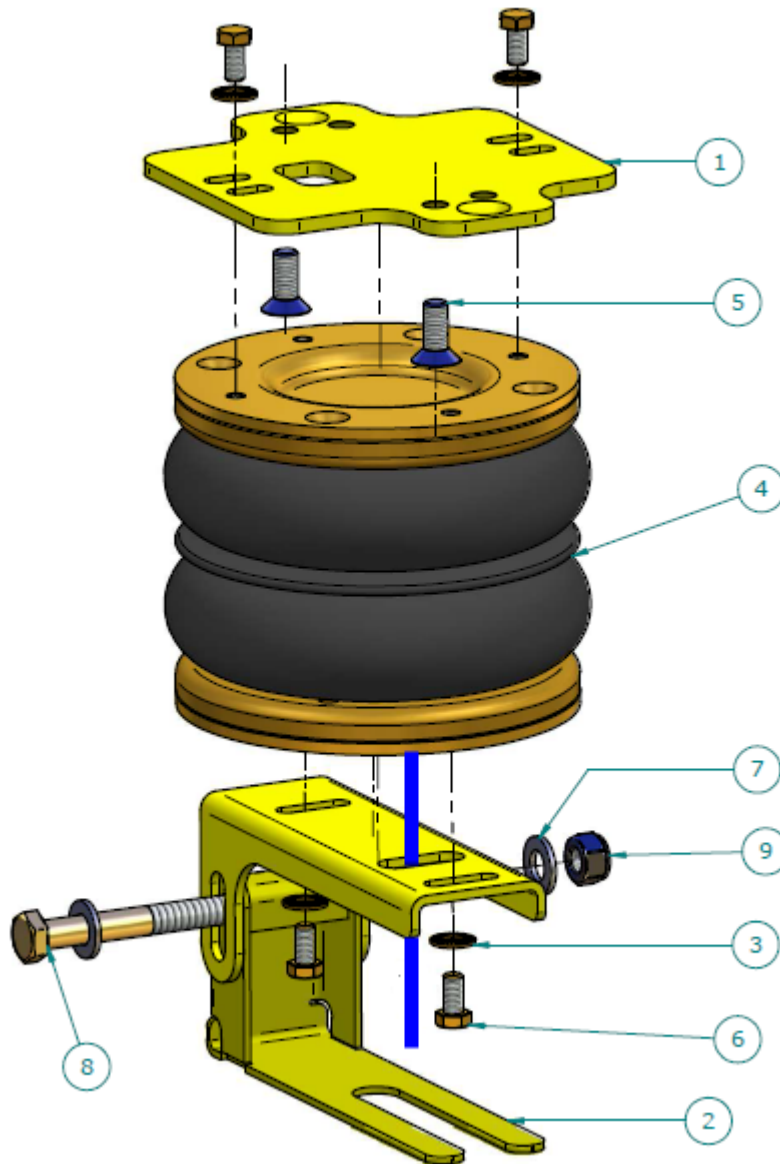

Not in the assembly drawing...

- The left side
- Black hose
- Tie wraps
- Any inflate option
- Declaration of conformity
- Installation manual

## L.NAV.14.C.M

### 5. INSTRUCTIONS FOR INSTALLATION



#### Preparation and Precaution

Before beginning installation, ensure that you have sufficient clearance between the axle and the chassis. Use a jack if necessary. Install at one side of the vehicle at a time.



Pay attention to your safety at all times during installation - always use axle stands to support the vehicle!



The position of the axle stands should be under the chassis NOT under the axle!

#### 5.1 Recommended Tightening Torque

During fitting of the air suspension system, it is recommended that nuts and bolts are tightened in accordance with the following table...

METRIC TORQUE CHART in N.m			
SIZE	CLASS 8.8	CLASS 10.9	Aluminium and PA6G
M6 x 1	10	14	4
M8 x 1.25	23	34	9
M10 x 1.25	51	72	20
M10 x 1.5	48	67	18
M12 x 1.75	83	117	31
M16 x 2	200	285	80

- When both the bolt and nut are made from steel use either class 8.8 or 10.9
- For all other materials, tightening torque is left to the discretion of a person skilled in the art

The following instructions make reference to the diagrams on page 13.

#### 5.2 Preparation

- i. Secure the front wheels, use wheel chocks on both sides of both front wheels.
- i. Take the ground terminal from the battery when work to electricity is involved.
- ii. Lift the rear of the vehicle till there is working space of approximately 25 cm between bump stop and rear axle.



## L.NAV.14.C.M

### 5.3 Attaching top plate to chassis

1. Remove the bump stop. (pictures 1)
2. Install the upper plate with the M8 counter sunk bolts on the place of the bumps stop. (pictures 2)
3. The middle line of upper plate has to be outwards. (pictures 2)

### 5.4 Installation of lower plate

1. Loosen the U-bolts, just enough to make it possible to slide in the fork of the lower bracket in between the axle and the leaf spring (app. 7 mm). Depending of what year the vehicle is chose to install the bracket from front to rear or from rear to front, choose the side with the less obstacles like hand brake cables, brake lines or wiring. (pictures 3 to 5)
2. Align the other part of the lower bracket parallel to the fork. Do not tighten the bolts and the u-bolts yet.

### 5.5 Installation of the air spring

1. Bring the air lines true the big hole of the lower plate, black is left end blue is right. (pictures 6 and 7)
2. Connect the air hose to the air bellow (see also 5.7)
3. Place the bolts with disc washers. Leaf some clearance to allow aligning the air spring. (see also 5.5)

### 5.6 Spring Alignment

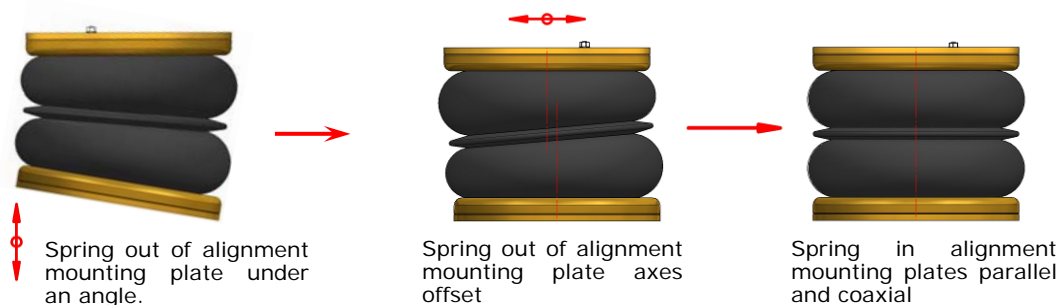

#### CAUTION!

- i. With the vehicle standing at the desired ride height, ensure that the springs are correctly aligned as illustrated above and then tighten the bolts to secure the bellow (bellow height approximately 13.5cm) to both the upper and the lower mounting brackets.
- ii. Always check if the air bellow won't touch any obstacle



## L.NAV.14.C.M

### 5.7 Fitting of Inflator Console

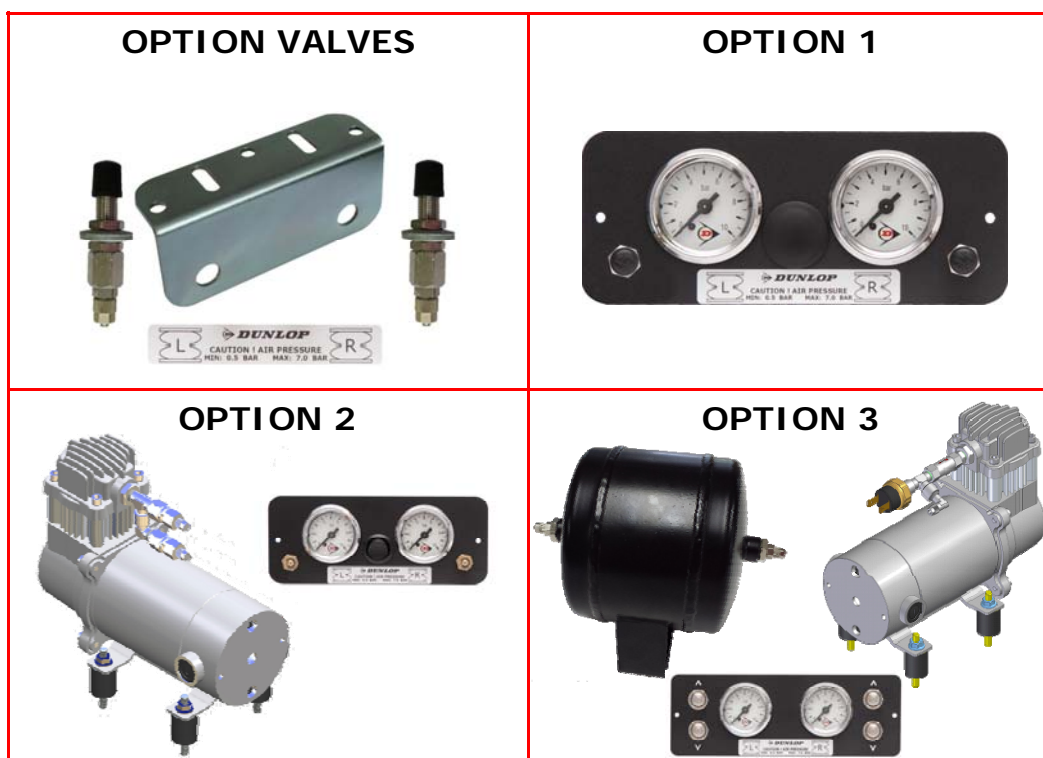

Your kit is supplied with one of the inflator options shown above...

- **OPTION VALVES** : Two valves and a small bracket
- **OPTION 1** : Two valves in a console with two independent 10-bar pressure gauges
- **OPTION 2** : Two valves in a console with two independent 10-bar pressure gauges and a rocker on/off switch to operate the electric motor driven air compressor
- **OPTION 3** : Four valves (two for raising the vehicle ('UP') and two for lowering the vehicle ('DOWN')) in a console with two independent 10-bar pressure gauges. A pressure switch operates the electric motor driven air compressor to keep the air reservoir of 1.9-litre at pressure.

## L.NAV.14.C.M

Mount the console in a position of your choice whereby it is firmly fixed, has some protection from the environment (particularly important for the console with gauges) and is easily accessible. Suggested possible locations include...

### 'Option Valves' Console...

- on the rear bumper
- at the rear beside the license plate
- on the chassis next to a rear wheel
- in a service shutter (motorhomes)
- beside the fuel cap

### 'Option 1', 'Option 2' or 'Option 3' Console...

- in the vehicle cabin, within reach and sight of the driver
- Beside, under the driver seat
- in the wall of a cupboard (motorhomes)
- in a service shutter (motorhomes)

### 'Comfort' Packages

The 'Option 2' and 'Option 3' panels, as shown above, are each part of a *Comfort Package* that is supplied with a compressor (and also an air reservoir in the case of the 'Option 3' panel) for ease of spring inflation and ride height setting. For further information please ask your dealer.

The picture below shows all of the parts of Comfort Package 'Option 2'...



Comfort Package 'Option 2'

## L.NAV.14.C.M

### 5.8 Tube Connection and Disconnection, Cutting and Routing

#### Connection and Disconnection

Tubes are connected as shown by the diagrams below...

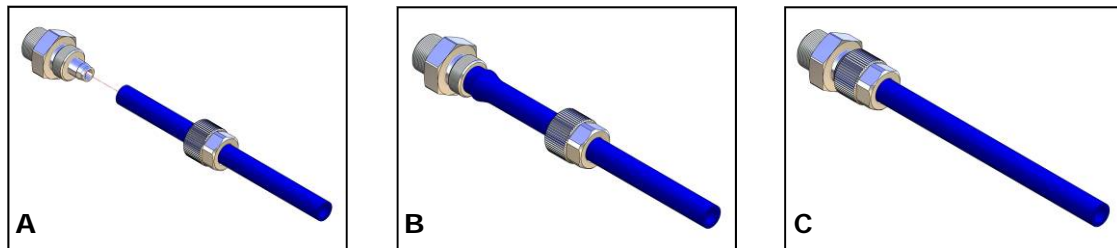

- A. Slide a nut over the end of the tube
- B. Push the tube onto the connector as far as possible
- C. Feed the nut up to the connector, fully tighten by hand and finally tighten one additional turn using spanners

#### Cutting

To achieve good sealing and air-tight fitting of tube ends to their connecting parts, it is very important to cut tubing cleanly and squarely. A dedicated guillotine action tubing cutter is recommended, or a craft knife if such a tool is not available. Do not use electrician's side cutters.



A dedicated tubing cutter -  
**Recommended**



Electrician's Side Cutters  
**NOT Recommended**

## L.NAV.14.C.M

### Routing

Study the underside of the vehicle and decide how to route each branch of the air circuit...

- To minimise the risk of chafing, avoid running tubing over metal edges as much as possible
- Avoid close proximity to heat sources such as the exhaust assembly
- Choose a route that provides as much protection as possible from dirt, debris and any solid objects that may impact the underside of the vehicle

It is recommended that tubes are guided alongside brake lines as much as possible.



Use cable ties ('tie wraps') to secure tubing to the chassis, taking care not to over-tighten them.

### 5.9 Spring Inflation

Once installation of the air assist kit is complete, inflate the springs via the inflator console taking careful note of the following...



#### Maximum and Minimum Pressure

**Maximum Pressure 7.0bar**      **Minimum Pressure 0.5bar**

Do not exceed 7.0bar (101psi), which is the recommended maximum charge pressure for the air springs.

The springs may be deflated if the vehicle is to be stored for a lengthy period without use, but a pressure of at least 0.5bar (7.25psi) should be maintained at all times in order to avoid possible compression damage to the springs.

With the vehicle standing at the desired ride height, it is recommended that the height of the bellow itself should be between 12cm and 15cm.

It is wise to hand over the vehicle 24 hours after the installation is done. Just to assure the customer will leave with an airtight system.



D23

Nissan Navara NP300

D23

## L.NAV.14.C.M

### 5.10 Maintenance

Following installation, it is recommended that all metal parts are coated with a protective substance such as body wax.

The system does not require very much maintenance other than...

- ◆ to maintain air pressure in the springs. Much like a tyre, the system may lose a little air over time.
- ◆ to keep the air bellows clean. It is suggested that, when washing the vehicle, the bellows are inspected and cleaned as necessary (preferable by spraying). Look in particular for stones or grit trapped between convolutes, as this may damage the bellow.
- ◆ Check before and after the winter period the wax coating. Re-wax when necessarily

### 5.11 Check List

Before driving the vehicle following completion of installation of the auxiliary air suspension system, please check...

- ...all bolts tightened to the recommended torque (Page 8)?
- ...air springs set in alignment (Section 5.6)?
- ...enough free space around the air springs to avoid wearing?
- ...all metal parts wax coated (Section 5.9)?
- ...manufacturer's declaration form completed and a copy returned?



A wait of 24 hours is recommended in order to ensure that the vehicle has maintained its stance and that there are no air leaks present.

**L.NAV.14.C.M**

**5.12 Installation Pictures**

1



2



3



4



5



6



**L.NAV.14.C.M**

7



8





D23

Nissan Navara NP300

D23

## L.NAV.14.C.M

### 6. EPILOGUE

DSC Nederland hopes that you enjoy the benefits that your *DUNLOP* air suspension system will provide for you. To ensure optimal performance, we advise that you have your system checked frequently by qualified personnel. As recommended in the fitting instructions, it is important to coat all the steel parts with a protective substance such as body wax.

#### **IMPORTANT : Manufacturer's Declaration Form**

**A manufacturer's declaration form is provided with your kit. Following installation of the kit please ensure that this form is completed, signed by a qualified fitter and a copy is returned to DSC Nederland by post, fax or e-mail. Our e-mail address is: [info@dunlopsystems.nl](mailto:info@dunlopsystems.nl)**

As a condition of your warranty, modifications to the system may only be carried out by personnel of DSC Nederland.

#### **Enquiries**

For general enquiries please contact one of our dealers. You can find them on our website.

[www.dunlopsystems.nl](http://www.dunlopsystems.nl)





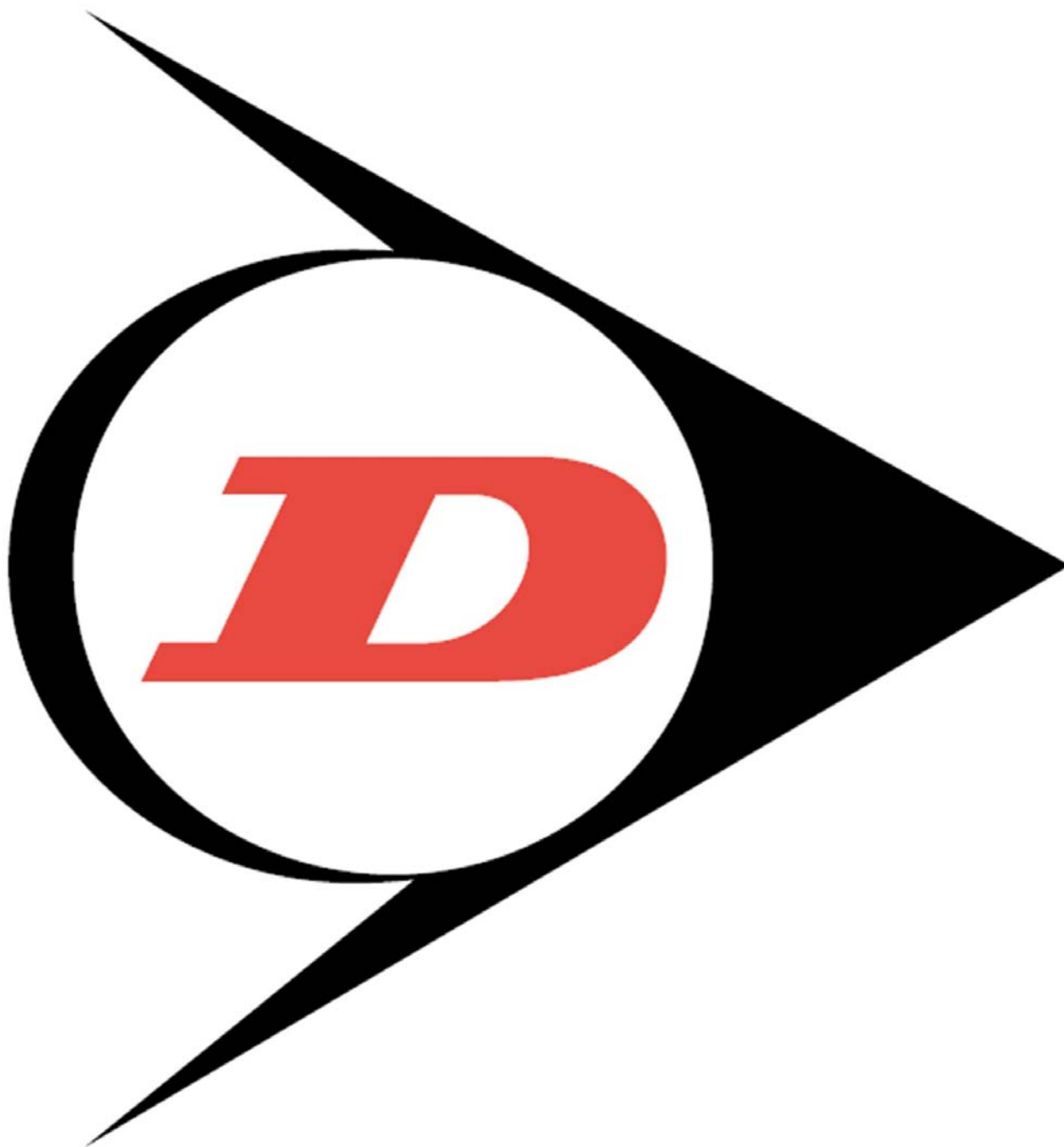

DSC Nederland B.V.  
Het Wegdam 22  
7496 CA Hengevelde  
Nederland  
Tel. : +31 (0)547 333065  
Fax. : +31 (0)547 333068  
e-mail: [info@dunlopsystems.nl](mailto:info@dunlopsystems.nl)

[www.dunlopsystems.nl](http://www.dunlopsystems.nl)